

SKYNAPTICS

INFOTAINMENT & MEDIASOLUTIONS

GLASS LED DISPLAYS



INTERESTED IN A TRANSPARENT LED DISPLAY FOR YOUR BUSINESS?
CONTACT US OR CALL US



SKYNAPTICS LTD & Co KG
Feldgasse 25, A-2454 Sarasdorf

+43(0)699 1000 49 16 

fiedler@skynaptics.com 

www.skynaptics.com 

Patrick FIEDLER
Chief Financial Officer



www.skynaptics.com

PRODUCT INTRODUCTION

Skynaptics Glass LED use high density industrial tempered glass as the base material to combine with their patent- ed integrated-IC technology and its applied Nano film circuits. These techniques combined, gives way to a super-high transparency and high energy efficient glass LED display. This products is widely used for building facades (as architectural lighting or advertising displays), commercial spaces, elevator facades, balustrades of mall atriums, retail windows and so much more. The glass LED can be used as construction component glass for new buildings, or simply attached at the rear of current existing glass facades.

The glass LED will definitely give value to any new or existing glass facades, enabling it to become a revenue generator media display, not only an architecture structure. The Skynaptics LED glass will open many new possibilities for architects and designers on creativity and structure designs.



CORE TECHNOLOGY

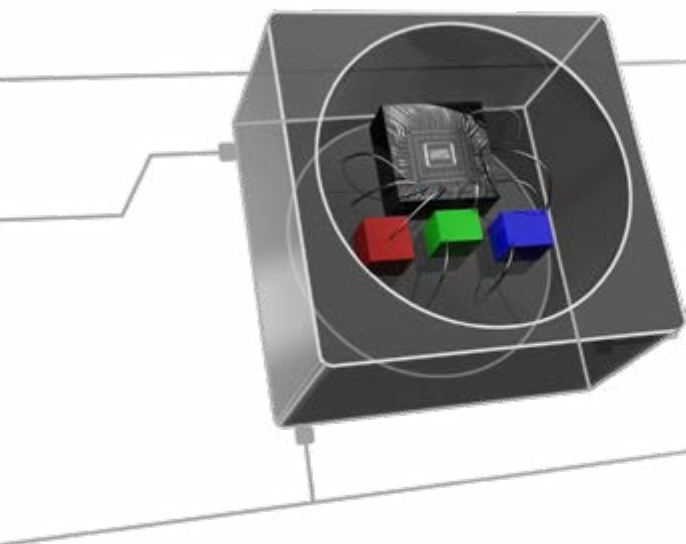

PATENTED INTEGRATED-IC TECHNOLOGY

Our self-developed IC driver is integrated directly into our lamps, this design and technology gives way to a much simpler circuit architecture, limiting and controlling heat dissipation and current stability.

PATENTED TECHNOLOGY

EASIEST WIRING DESIGN

Embedded IC driver technology, three trace connectivity, simplest design, smaller pixel pitch and best transparency performance.

DUAL DATA BACKUP TECHNOLOGY

Dual data backup technology will prevent data loss if an LED is shown having a problem. Data will be automatically re-directed.

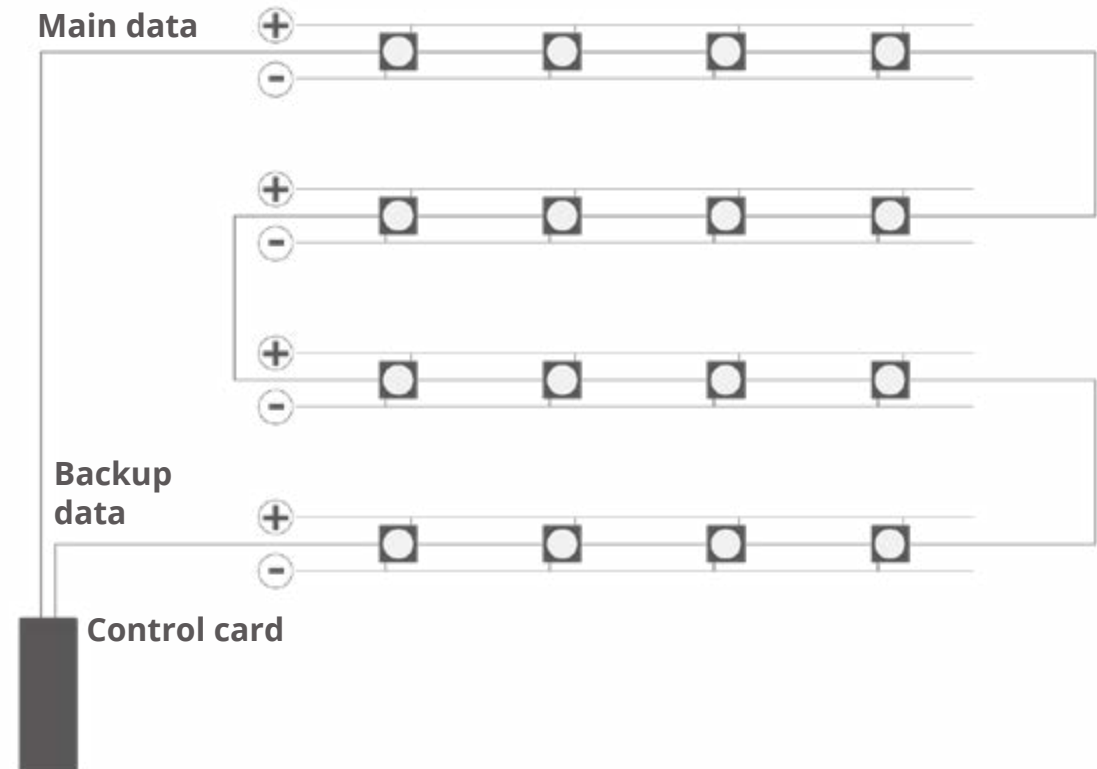

SECURITY



FIRE RESISTANCE
Flame retardant



HIGH STRENGTH
Tempered laminated glass, ensuring personal safety



POWER GROUND PROTECTION
Low 5V output, electrical shock prevention safety



IP65 WATERPROOF AND DUSTPROOF
Keeping the screen in normal working condition, even if water or dust is found.

APPLICATIONS



CURTAIN WALLS



SHOPPING MALL ATRIUM BALUSTRADES



RETAIL SHOP WINDOWS



ELEVATOR SHAFTS

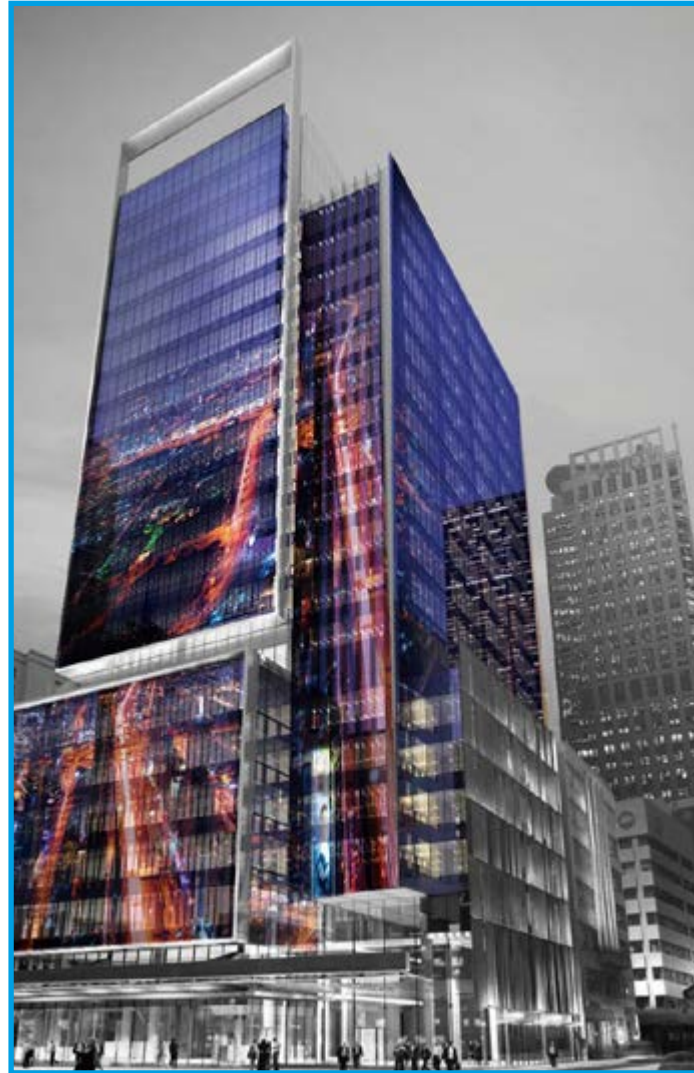

BUILDING LIGHTING

APPLICATIONS



ESCALATOR BALUSTRADES



SKY SWIMMING POOLS



INTERIOR SLIDING DOORS / PARTITIONS



CEILING BACKGROUNDS



DIRECTIONAL & INFORMATION SIGNS

SKYNAPTICS

PRODUCT FEATURES

THIN

Ultra-thin and light-weight 7mm and 15kg/m²

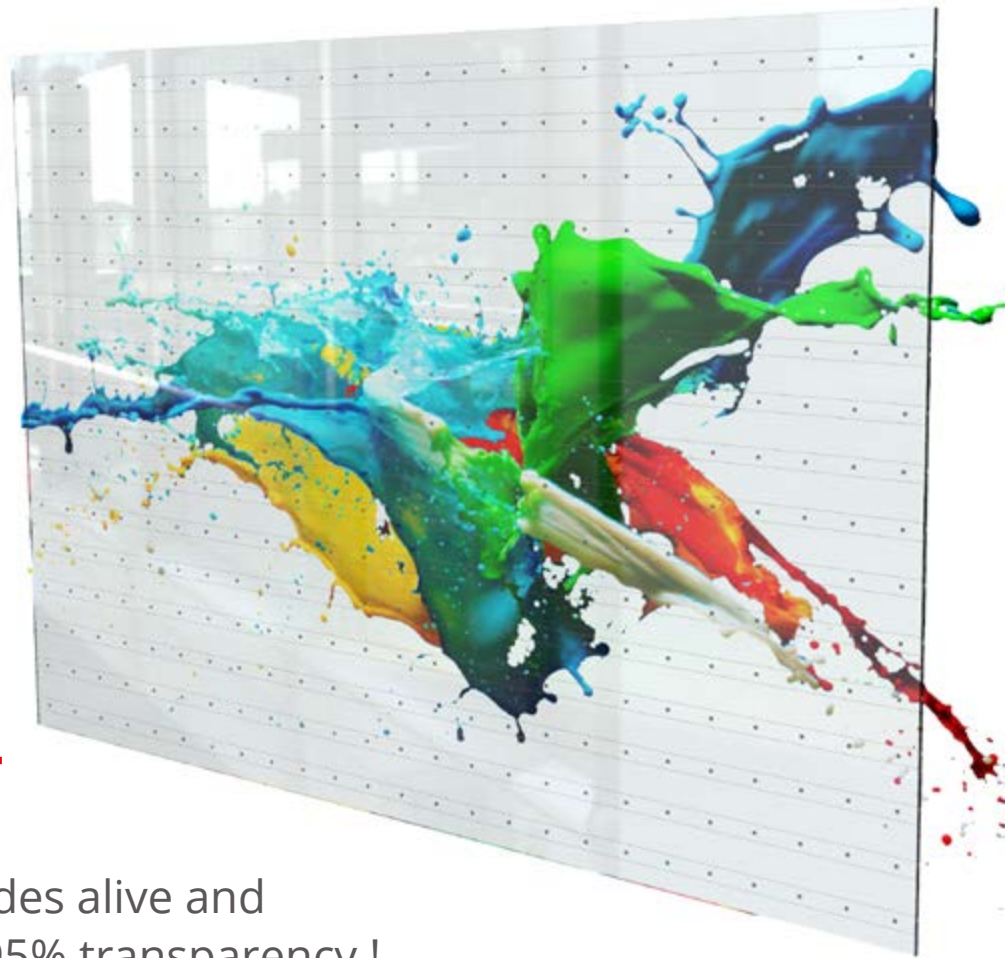

TRANSPARENT

Keeping the visual effects of glass facades alive and dynamic with over 95% transparency!

PRODUCT SIZE CHART

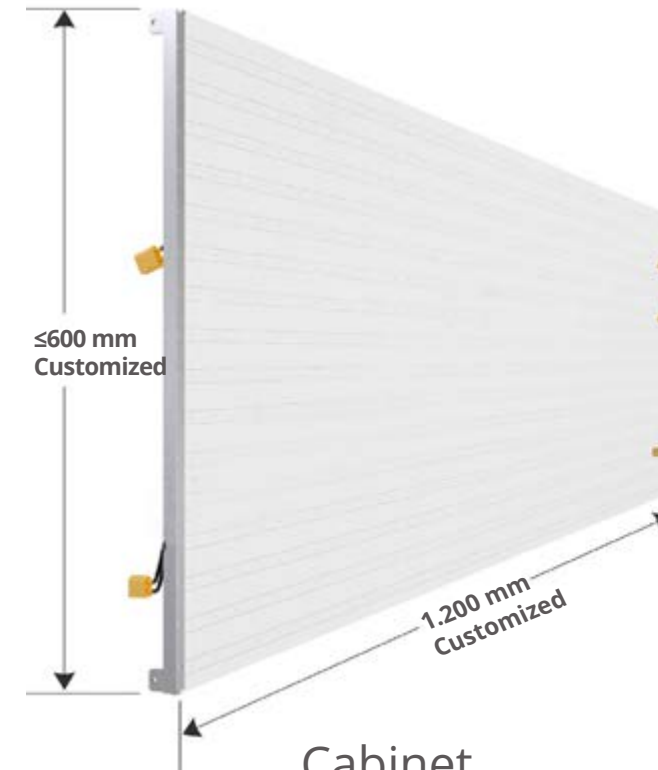

Cabinet
Axonometric
Illustration

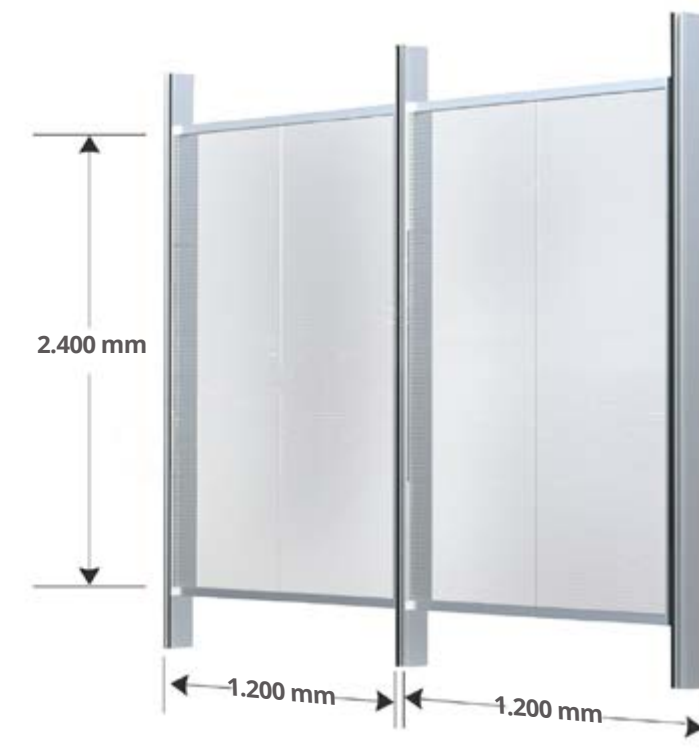

Cabinet Splicing
Illustration

PRODUCT SPECIFICATIONS

Model	NE10	NE15	NE20	NE25	NE30
LED	SMD2020	SMD2020	SMD2020	SMD2020	SMD2020
Resolution(dot / m ²)	9216	4096	2304	1600	1024
Pixel Pitch(mm)	10.42x10.42	15.62x15.62	20.84x20.84	25.00x25.00	31.25x31.25
Brightness(nit)	4000~4500	3000~3500	2000~2500	1500~2000	1000
Display Size(mm)	1000x500	1000x500	1000x500	1000x500	1000x500
Max. Power(W / m ²)	800	650	500	380	200
Avg. Power(W / m ²)	300	250	180	150	120
Transparency	90%	93%	95%	96%	97%
Protection Level	IP65	IP65	IP65	IP65	IP65
Refresh Rate(hz)	≥3840	≥3840	≥3840	≥3840	≥3840

STRUCTURE DIAGRAM

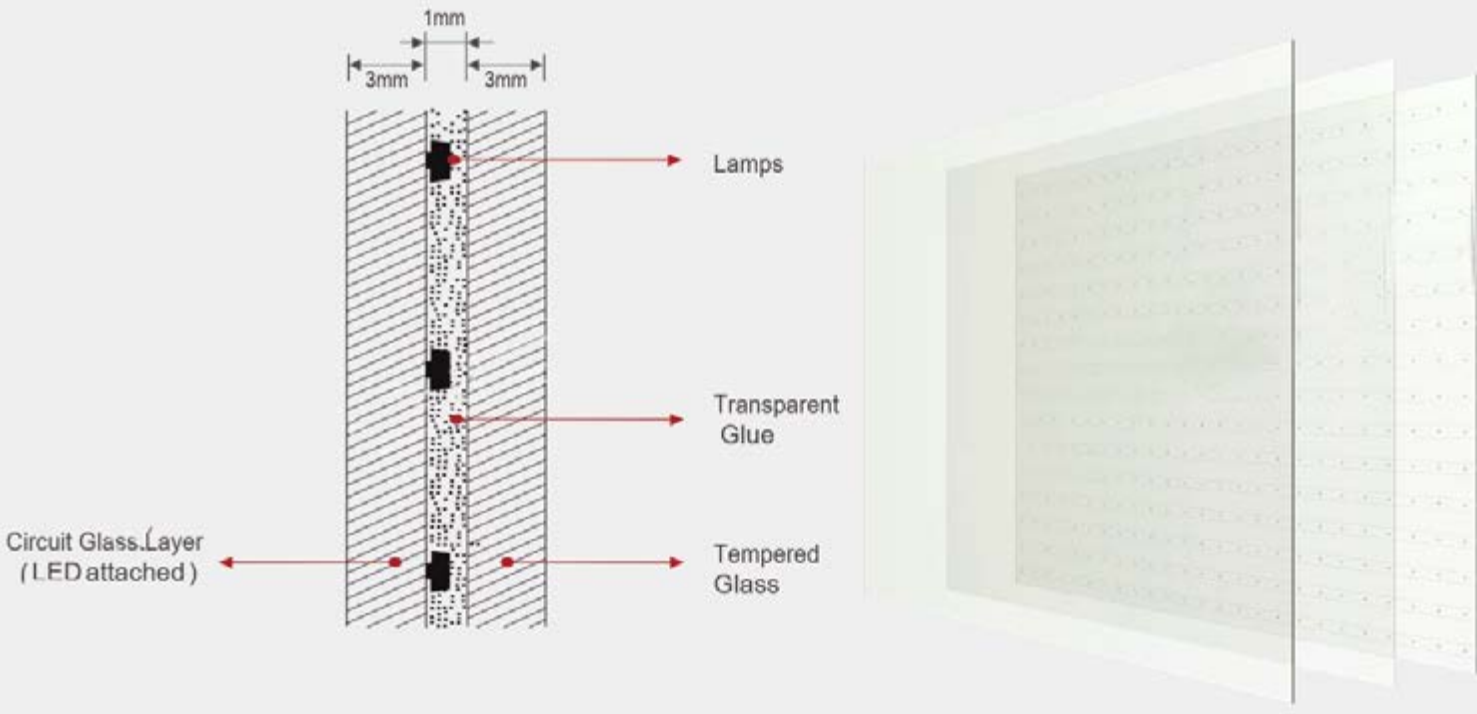

APPLICATION STRUCTURE DRAWING OF CURTAIN WALL GLASS

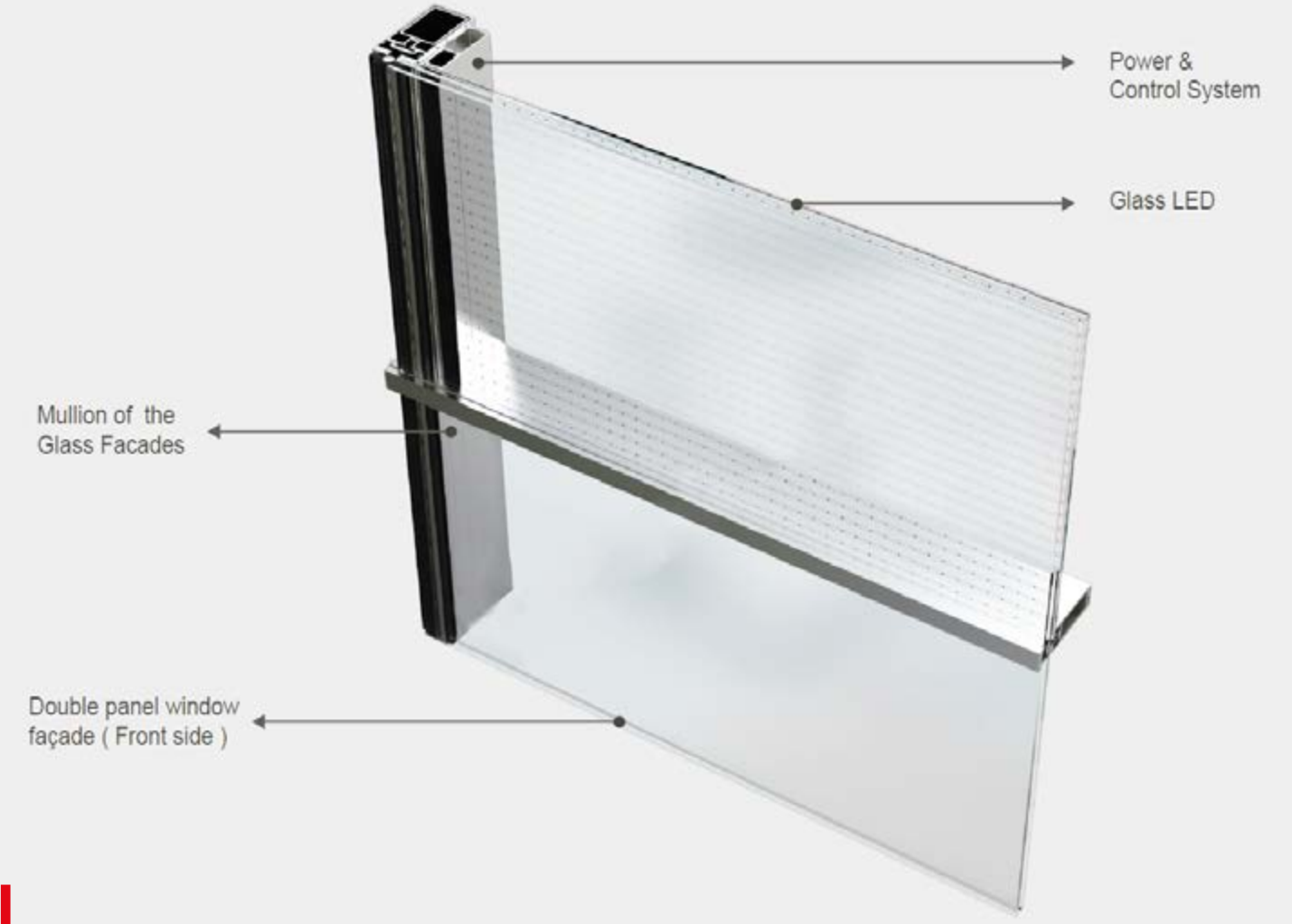

APPLICATION STRUCTURE DRAWING OF CURTAIN WALL GLASS

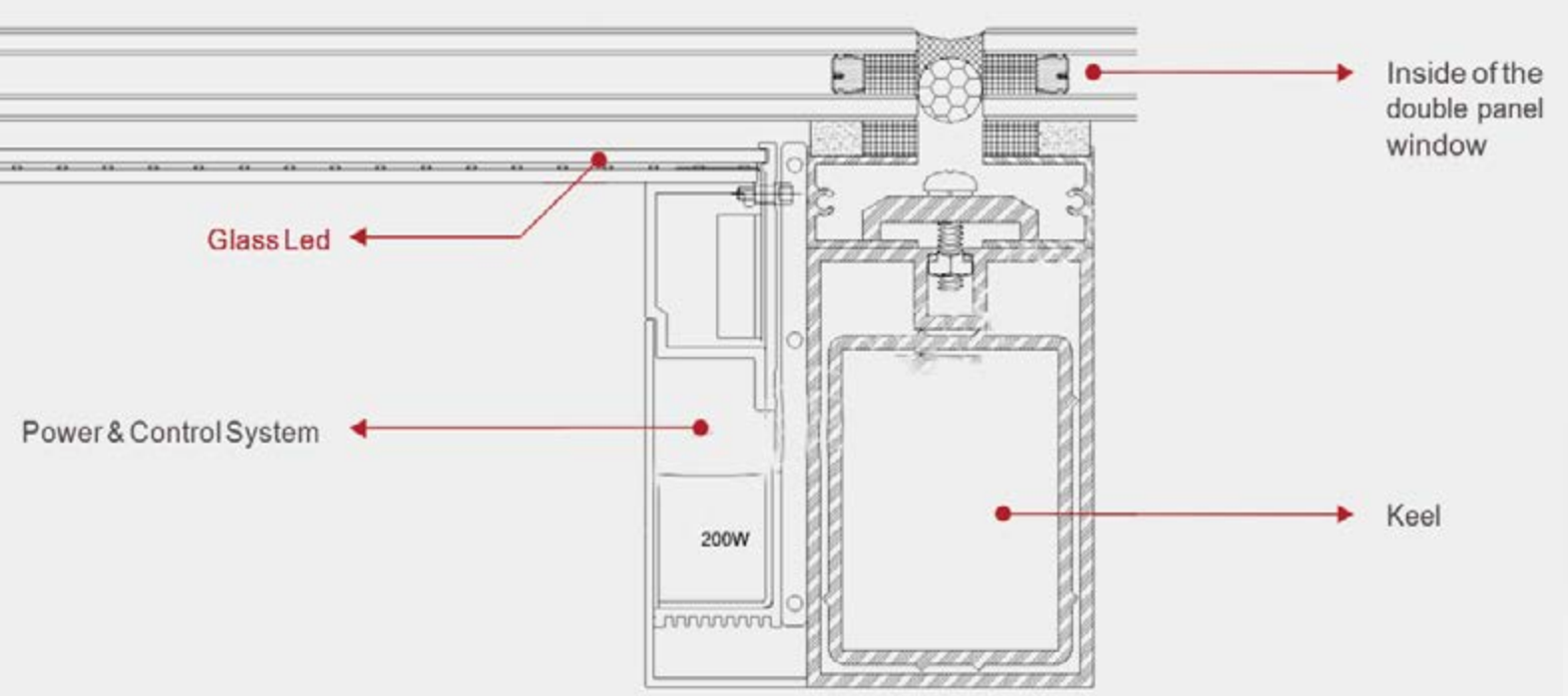

BALUSTRADE APPLICATION STRUCTURE DRAWING



TRANSPARENT DIGITAL POSTER

Solves the advertisement for a variety of Retail chain stores



FOR WINDOWS ADVERTISING ALL AROUND THE WORLD

Dual Transparent digital poster is the best advertising solution for any shopwindows. It can not only update contents easily and won't block lighting like printed posters but can also remotely and collectively control many screens. Thanks to great improvements in brand image and publicity, transparent digital poster is the most powerful and creative advertising carrier.



BENEFIT



Unparalleled Transparency



Easy Setup



Light Weight



High Brightness



Central Control



Easy Maintenance

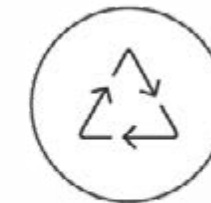

Energy Efficiency



Cost Efficiency



Stable Performance



Transparent led poster awarded with IF in 2017



CENTRAL CONTROL

The display read almost any video and images content format such as jpg, jpeg, png, mov, wmv, mp4, etc. You can remotely control, monitor and update content from a control server. Make sure communication to your customers are instant and synchronized.

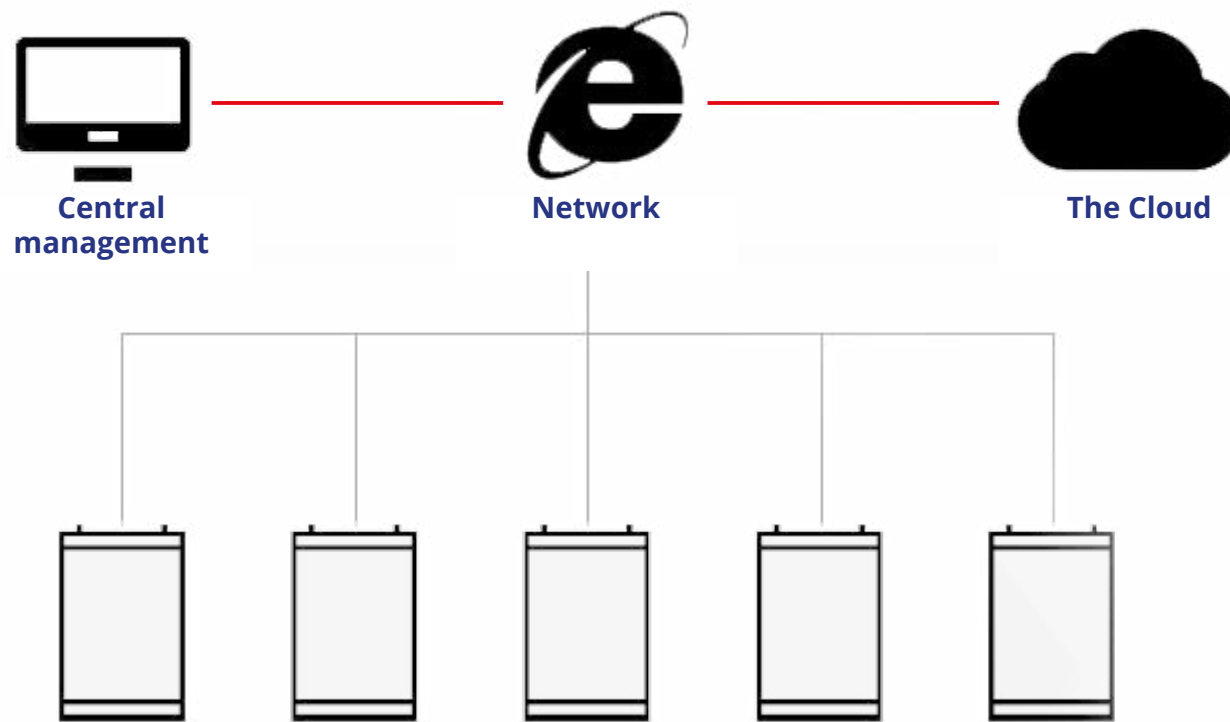

TRANSPARENT DIGITAL POSTER

Model	LED	Resolution (dot/m ²)	Pixel Pitch (W X H)(mm)	Cabinet size (W X H)(mm)	Cabinet Resolution	Brightness (CD/m ²)	Transparency
2.0S	SMD1515	59904	2.05x5mm	670x1120x49mm	312x192	4500-5000	68%
2.1M	SMD1515	98304	2.12x4.7mm	841x1360x49mm	384x256	4500-5000	66%
2.6M	SMD1515	59904	2.6x5.9mm	841x1292x49mm	312x192	4500-5000	73%
2.5L	SMD1515	86016	2.5x5.71mm	990x1440x49mm	384x224	4500-5000	72%
5.0L	SMD1515	43008	5.0x5.71mm	990x1440x49mm	192x224	4500-5000	72%

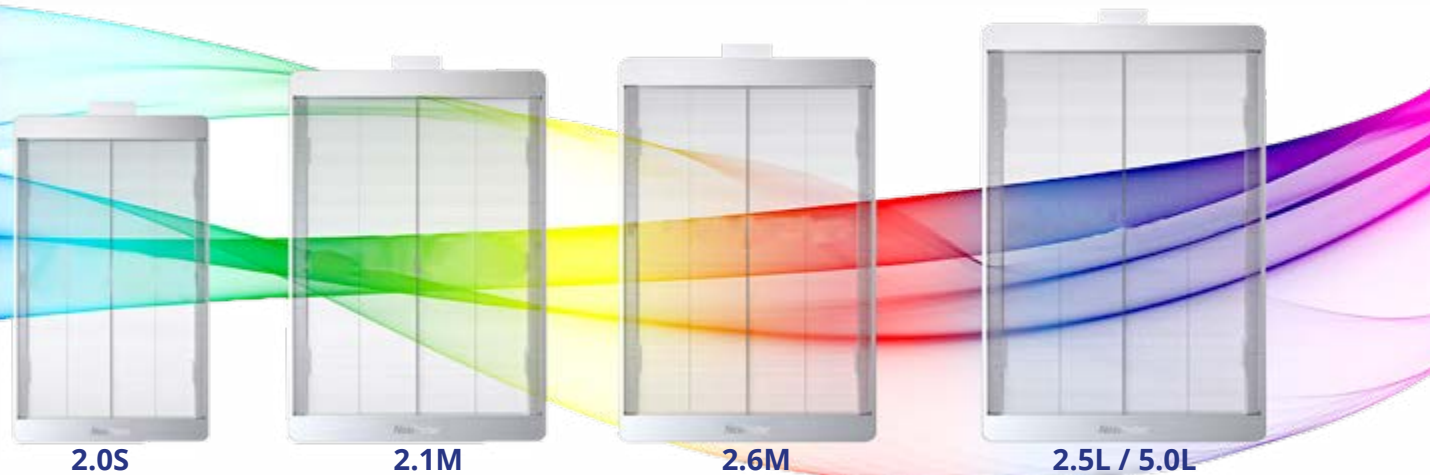

CONNECTING YOUR SMART POSTER WITH THE CLOUD

SKYNAPTICS



A COMPLETE DATABASE OF CONTENT FOR YOURS NEEDS.

We have content available for most of all retail market segments. Simply pick and choose the picture or animations you desire then update your Smart posters anywhere at any given time!



LOADS OF TEMPLATES TO CHOOSE FROM!

Our team of professional designers have created loads of fresh templates for your picking. Easy to edit and tailor to your need oof the moment! JPG, PNG, MOV, WMV, MP4 and more formats are available.

SKYNAPTICS



TRANSPARENT DIGITAL POSTER "NE"



MULTIPLE INSTALLATIONS ARE AVAILABLE

sizes and methods of installations. These Smart Poster are easy to use and will attract you audience's attention. Get your customers in your stores!

A-Frame Stand

Free standing

Floor standing (indoor)

Standing on window ledge (indoor)

Hanging (indoor)



"SKYNaptSign"

ULTRA-TRANSPARENT GLASS LED DISPLAY

VIDEOS VIEW



Skynaptics SN-series, also called as transparent digital poster solves the advertisement for a variety of Retail chain stores.



Transparent & Thin



High-Tech Design



Cloud Base Services



Green / Eco-Friendly



Waterresistant & shatter proof



Inter-Linkable



„SKYNaptSign“ is on ultra-transparent glass LED display using NEXNOVO´s patendend integrated-IC technology and nano film circuits. This display has an all-in-one cloud base content creation & management application, allowing a complete central administration. It is the new generation of smart high-tech displays that brings innovation to any and most markets requiring efficient and avant-guard signage.

Research and development of integrated-IC technology

We make brighter displays
We make displays more vivid and responsive



LIGHT, TRANSPARENT & THIN



10 kg/panel

92% transparency

Simple, sleek and see-through daylight friendly displays.

7.5 mm slim

INTER-LINKABLE



EASY INSTALLATION
Ease and simplicity of operation

Power cable

Inter-link data cable

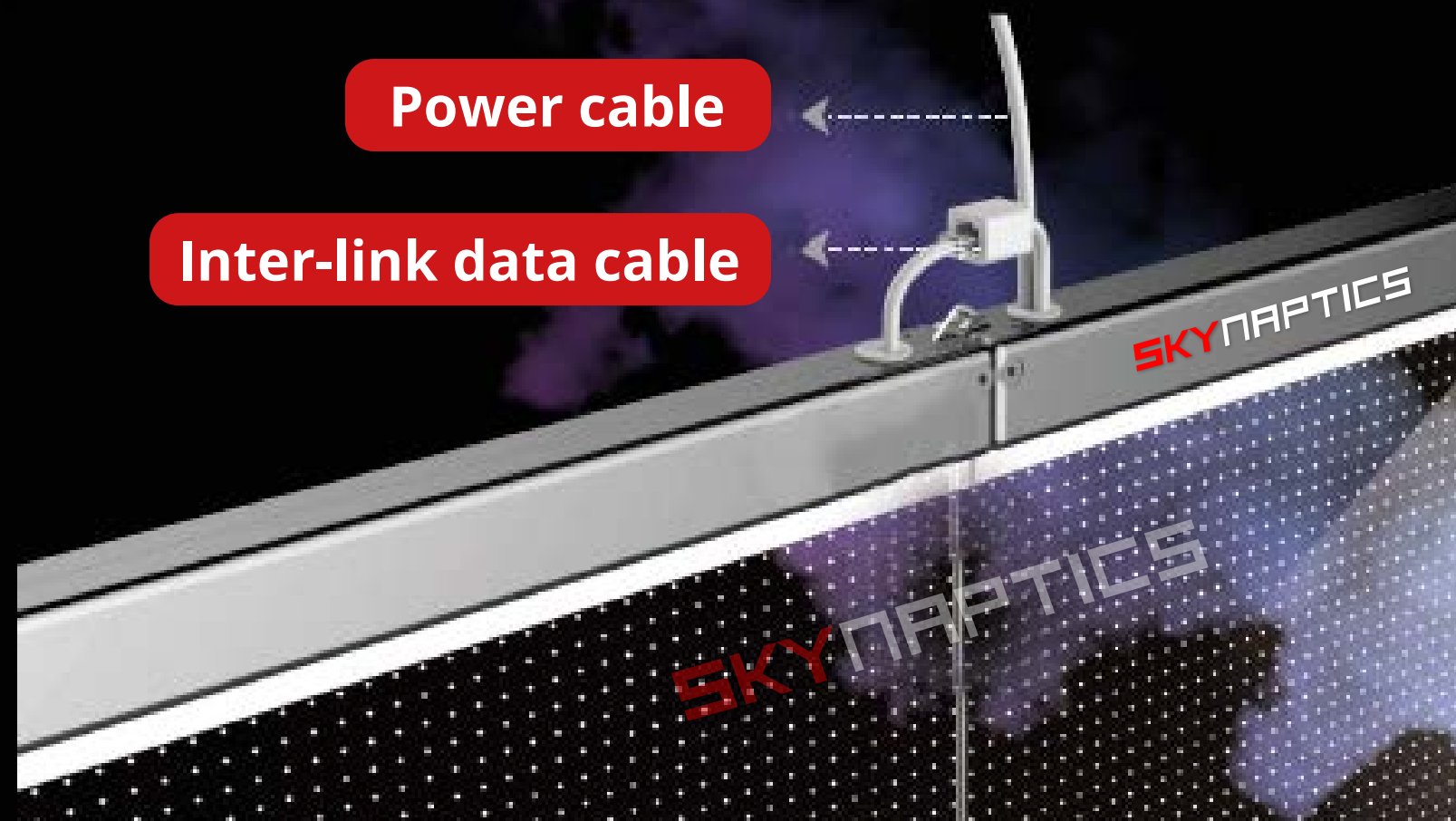

SKYNAPTICS

LET'S DO IT.



Easy and centralized management

- ◆ NexCloud services or HDMI input.
- ◆ NexCloud is a web platform where publishing content is made easy.
- ◆ "One-click" easy publish and remote management on your mobile phone or on the web portal.
- ◆ Professional customized content services are available.



Create & Publish yourself

Multiple libraries of content are available, such as; fonts, backgrounds, animations and many more templates.

Decide on a template, customize, and then publish!

Making content designing a breeze.

Be your own design specialist.

SKYNAPTICS



Text editing



Images Library



Background Library



Publish



Stay in control with centralized management

Support flexible and simple hierarchical policies. Never has content publishing been so flexible and safe.

SKYNAPTICS

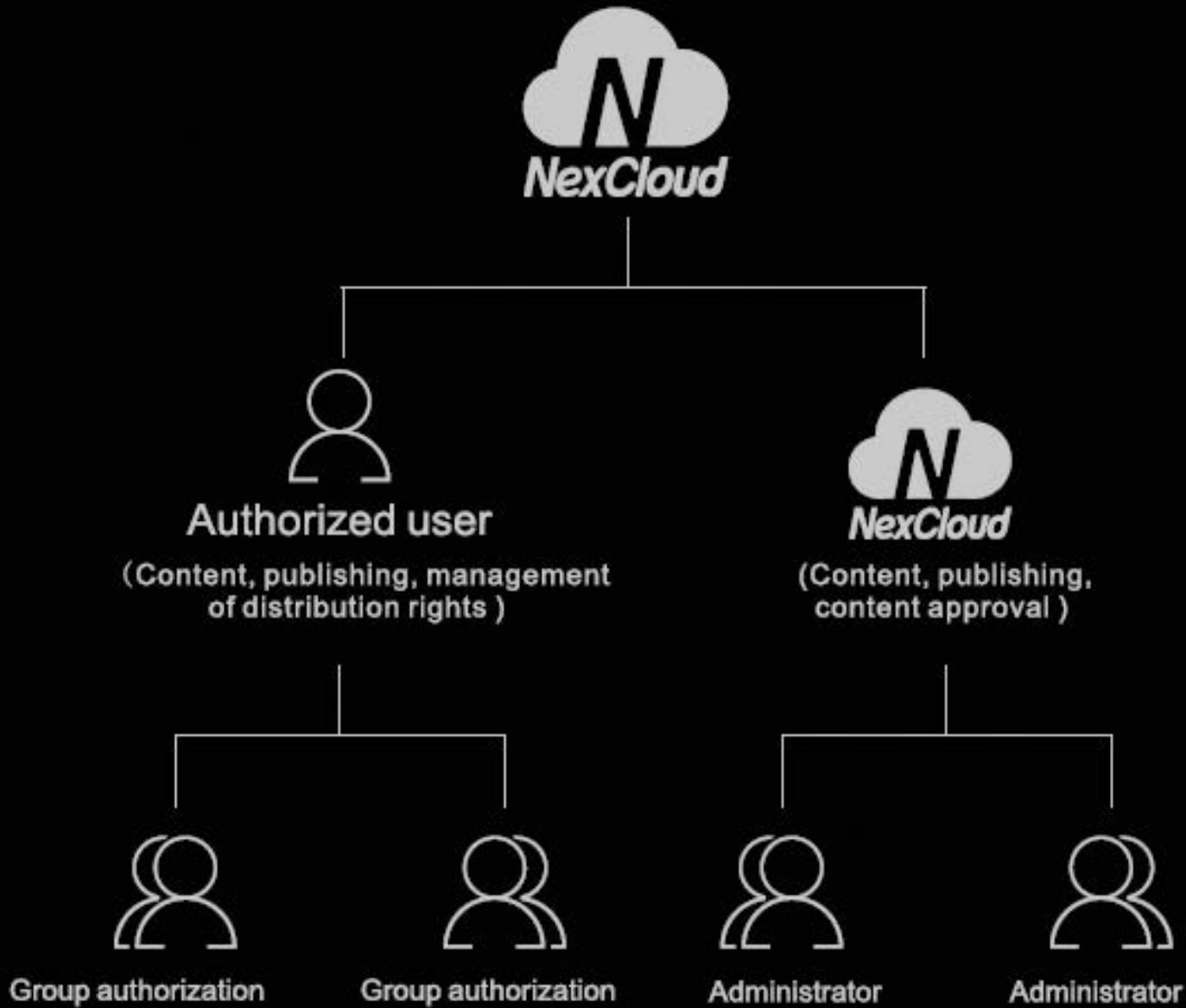

SKYNAPTICS

„SKYNaptSign“ is versatile, use it for simple way finders, critical information displays or just amazing advertisers. In environment such as; airports, train stations, retail stores, healthcare, education system, corporate offices, food and beverage industry, tourist sites and much more.





Model	NT
LED model	NEX2020-T
Display size (WxH) (mm)	800 x 500
Cabinet size (WxH) (mm)	800 x 575
Pixel density (dot)	3648
Pixel pitch (mm)	10.52 x 10.42
Brightness (cd/panel)	4000-4500
Max. power (W/panel)	240
Ave. power (W/panel)	120
Transparency	92%
Weight (kg/panel)	10
Ingress protection	IP65
Refresh rate (Hz)	≥1920

DIFFERENCES BETWEEN NE AND NT SERIES:

Both „NE“ and „NT“ uses „Nexnovo“ patented integrated-IC technology where IC drivers are integrated into our LED lamps. It gives way to much simpler circuit design and high transparency up to 90%.

Typ „NE“

- is highly-customized solution for various glass facade advertising media solutions
- it is modular design and can be assemble to fit any facade size
- it can be both fitted behind the glass facade and directly as dynamically informative glass facade



Typ „NT“

- is sort of like the poster which is the standard solution with fix size (800x500mm) for huge market potentiality
- it can be joined horizontally next to each other to form the transparent dynamic banner for all retail or corporate occasions



ABOUT US

OUR CERTIFICATIONS



CRESTRON:
101/P102/P201/
P301/DMC-D-4K/
DMC-E-4K/RL101/
NVX Design & Networking

SAMSUNG

CERTIFIED PARTNER
HOSPITALITY DISPLAY 2017

SAMSUNG:
Reach 4.0/
Hospitality Display/
Magic Info



MICROSOFT:
Microsoft
Certified



RUSSOUND
Certified Installer



ABSEN:
Certified Engineer



AV-Stumpfl Wings AV



LG: SuperSign/ProCentric



RTI APEX Certified



Loxone Certified Expert



KNX/EIB



BRAND CUSTOMERS

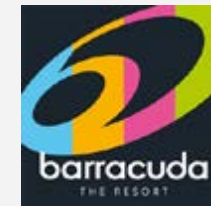

SKYNAPTICS LTD & Co KG

Feldgasse 25, A-2454 Sarasdorf Telefon: +43(0)699 1000 49 16

E-Mail: info@skynaptics.at Web: www.skynaptics.at